



OMEGA FOOT SWITCH

The LINEMASTER® Omega air foot switch is a uniquely designed air bulb suitable for both wet and dry environments. This completely sealed, smooth finish air foot pedal encases a weight plate that helps stabilize it on the floor and makes cleaning it a snap. The Omega switch offers the benefit of positioning the electrically live snap switch off the floor and away from the elements. This air bulb is supplied with 1/8" ID black PVC tubing, which connects the foot pedal to the remote air switch that is equipped with a 9/16" NF bulkhead mount. The remote air switch is SPDT and can be purchased in momentary or maintained versions. Special variations of the Omega air switch are available upon request. Only from LINEMASTER® - The leading manufacturer of foot controls in the world.



LINEMASTER Switch Corporation
Tel (860) 974-1000

29 Plaine Hill Rd, P.O. Box 238
Woodstock, Connecticut
06281-0238 USA
Fax (800) 974-FOOT(3668)



OMEGA FOOT SWITCH

FEATURES

- Developed for reliable operation in a variety of environments and to conform with UL standards
- Molded PVC bladder with smooth finish for ease of cleaning and long life
- Internal steel weight plate
- Up to a 30 foot range using black PVC tubing with .125" ID
- Designed with isolated electrical air switch; available in maintained and momentary actuation
- Stainless steel barbed fitting securely fastened to the weight plate for connecting the air tube to the bulb
- Ribbed design on top of the bulb for added traction and style



ACTUATING BULB

SIZE (Dia x H): 5.00 x 1.36 In.

WEIGHT: .80 lbs.

SNAP SWITCH

SIZE (H x W x D): 1.00 x .78 x .50 In.

WEIGHT: .15 lbs.

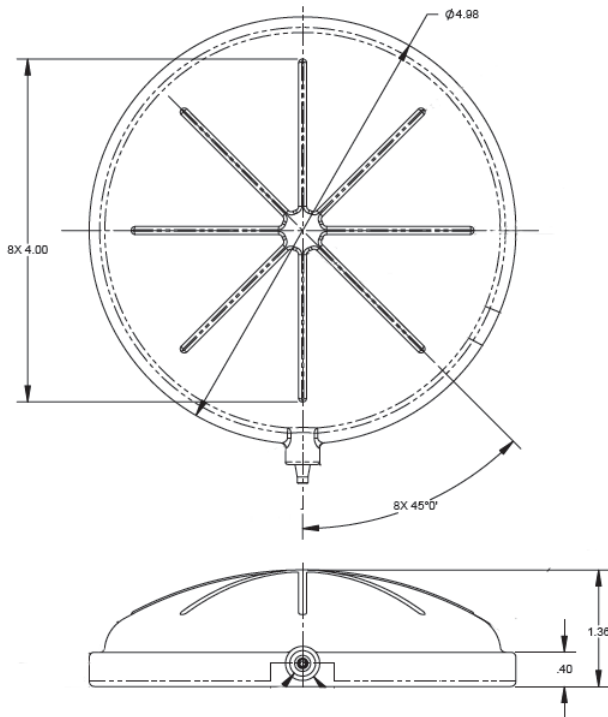

APPROVALS	EN 60529 DEGREE OF PROTECTION	CATALOG NUMBER	DESCRIPTION	COLOR	CIRCUIT	FORM	OPERATING TEMPERATURE RANGE	ELECTRICAL RATINGS
	IPXX	12SH12 ¹	Momentary	Black	SPDT	C	20°F to 120°F ²	20 A 125-250 VAC 1 H.P. 125 VAC 2 H.P. 250 VAC
	IPXX	12DH12 ¹	Maintained					

¹ Supplied with 10 ft. 1/8" I.D. black PVC tubing. ² The operating temperature range will vary with different lengths of tubing. Please consult the factory for details.