

HERCULES POTENTIOMETER FOOT SWITCH

POTENTIOMETER WIRING INSTRUCTION:

1.  **WARNING: TO AVOID PERSONAL INJURY, DO NOT USE THIS SWITCH ON MACHINERY WITH AN UNGUARDED POINT OF OPERATION.**

 **READ WARNING STATEMENT** on reverse side of this page.

2. When wiring up this device make sure **POWER IS OFF AND LINES ARE DEAD**.
3. **MAXIMUM FUSE RATING:** Amperage and voltage not to exceed nameplate rating – Quick Acting.
4. **Prior to wiring** the factory installed potentiometer, please note that the potentiometer body may move slightly with respect to the bracket when operating the foot treadle. This is to correct any eccentricity between the potentiometer shaft and it's body.

Do not tamper with this adjustment as the potentiometer may be damaged and/or the gear train may jam.

When wiring to a factory installed potentiometer, solder wire leads directly to the potentiometer terminals as assembled in the foot switch.

DO NOT REMOVE THE POTENTIOMETER or tamper with its adjustment or bracket for wiring, as the potentiometer has been properly set at the factory.

POTENTIOMETER REPLACEMENT INSTRUCTION:

1.  **WARNING: TO AVOID PERSONAL INJURY, DO NOT USE THIS SWITCH ON MACHINERY WITH AN UNGUARDED POINT OF OPERATION.**

 **READ WARNING STATEMENT** on reverse side of this page.

2. When wiring up this device make sure **POWER IS OFF AND LINES ARE DEAD**.
3. **MAXIMUM FUSE RATING:** Amperage and voltage not to exceed nameplate rating – Quick Acting.

READ the **INSTRUCTIONS THOROUGHLY** before replacing the potentiometer.

Prior to replacing the potentiometer, study the existing footswitch assembly to fully appreciate the following instructions:

USE the **SAME BRAND** and catalog number **POTENTIOMETER** that was originally supplied with the foot switch for best results.

IF THE REAR TRAIN OR ANY OTHER FOOT SWITCH PART IS DAMAGED OR ALTERED, RETURN THE FOOTSWITCH TO THE MANUFACTURER FOR REPAIR OR REPLACEMENT.

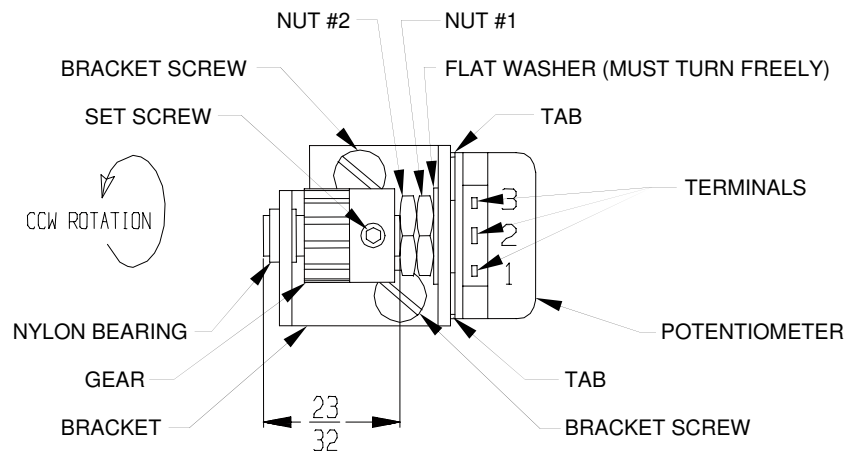

**DIAGRAM
"A"**

Refer to diagram "A" above for the following instructions:

Remove two bracket screws and remove the potentiometer/bracket assembly from the foot switch.

Loosen set screw, nuts #1 and #2 and remove gear, nuts #1 and #2, flat washer and old potentiometer from bracket.

Cut new potentiometer shaft to length; 23/32" long.

BEND TWO anti-rotational **TAGS** on potentiometer approximately 90°.

FACE potentiometer **SHAFT** and **TURN** shaft to **EXTREME CCW** (counter-clockwise) position.

Insert potentiometer into bracket with one flat washer, nuts #1 and #2 and gear.

Thread nut #1 onto potentiometer bushing and up against the flat washer with just enough finger pressure so that the **FLAT WASHER** can **TURN FREELY**. (The potentiometer should be able to move slightly with respect to the bracket to correct any eccentricity between the potentiometer shaft and it's body). Then thread nut #2 tightly against nut #1 using two wrenches.

Apply one drop of **MILD STRENGTH** anaerobic adhesive/sealant thread locking material to the gear set screw prior to assembly and tighten against potentiometer shaft. Make sure the thread locking material **DOES NOT WICK** into the potentiometer bearings.

With the foot treadle in it's up most position and the potentiometer shaft rotated in its CCW position mentioned above, insert the complete potentiometer/bracket assembly into the base. The intermediate gear (large gear) may have to be rotated slightly to properly align gear teeth.

Apply two drops of **MILD STRENGTH** anaerobic adhesive/sealant thread locking material to each of the bracket screws prior to assembly and tighten.

Depress the foot treadle through its full stroke to insure smooth operation. If the potentiometer gear does not mesh properly loosen the two bracket screws and adjust accordingly. **DO NOT FORCE** the **FOOT TREADLE** or tamper with the driving and intermediate gear train adjustments. **IF SMOOTH OPERATION** is **NOT OBTAINABLE RETURN** the foot switch **TO** the **MANUFACTURER** for repair or replacement.

Grease gear teeth and apply one drop of lubricating oil to the potentiometer shaft at the nylon bearing only.

IT IS IMPORTANT THAT THE POTENTIOMETER DOES NOT BOTTOM ON ITS INTERNAL STOPS before the foot treadle bottoms on the base casting. **TREADLE MUST BOTTOM** on the base before or at the same instant the potentiometer shaft has rotated to its internal stop. The same is true in its rest position; the foot treadle ears must rest on the bosses on the base casting with the potentiometer shaft on it CCW position stated above.

ADDITIONAL COPIES of this sheet are available upon request.