



EXPLOSION PROOF MEDICAL 500 & 600

The Medical Explosion Proof Foot Switch was designed to withstand abuse in the toughest environments while offering the end user a switch that is cosmetically pleasing. Equipped with an aluminum baseplate with nonskid conductive rubber basepad along with an integral handle, the Explosion Proof provides a solution that can easily be maneuvered, but has the weight to keep it from sliding around. Available in single pedal or twin pedal version to meet the needs of our customers. A high quality switch that lasts is what you can count on with the Explosion Proof. Only from LINEMASTER® - American made innovation at work.

LIT-036 Rev. D



LINEMASTER Switch Corporation
Tel (860) 974-1000

29 Plaine Hill Rd, P.O. Box 238
Woodstock, Connecticut 06281-0238 USA
Fax (800) 974-FOOT(3668)

www.linemaster.com

EXPLOSION PROOF MEDICAL 500 & 600

FEATURES

- Non sparking cast aluminum housing
- Aluminum base plate with nonskid conductive rubber base pad
- Both models prewired with potted connector MS-3102R-18-4PW
- Foot switch painted black
- Integral handle for ease of moving
- The two pedal model, wired with an electrical interlock, is supplied with a divider bar between pedals which helps prevent accidental operation of both pedals at one time
- Use mating connector MS-3106A-18-4SW, plus strain relief clamp MS-3057-10 or 10A
- Mating connector with cable clamp available from LINEMASTER® under cat. no. LSC-835
- Industrial models available

500 SERIES SPECIFICATIONS:

Class I, Division 1,
Group C & D
Class I, Zone 1,
Group IIA & IIB
NEMA Type 7C
EN 60529 Degree of
Protection IP41



EXPLOSION PROOF MEDICAL 500

SIZE (H x W x D): 4.38 x 9.75 x 10.00 In.

WEIGHT: 7.50 lbs.

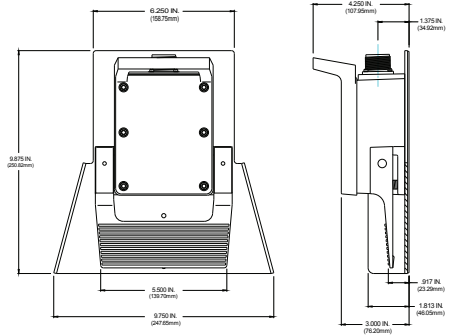

SINGLE PEDAL

600 SERIES SPECIFICATIONS:

Class I, Division 1,
Group C & D
Class I, Zone 1,
Group IIA & IIB
Meets IEC 60601-2-2



EXPLOSION PROOF MEDICAL 600

SIZE (H x W x D): 4.38 x 9.75 x 10.00 In.

WEIGHT: 8.00 lbs.

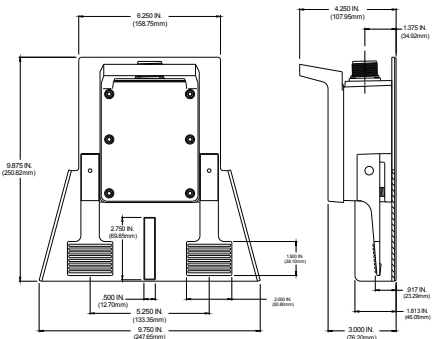

TWIN PEDAL

Agency Approvals	EN 60529 Degree of Protection	Catalog Number	Description	Circuit	Form	Wired	Electrical Ratings
	IP41	591-EX	Single Pedal - Momentary	SPDT	C	Pin A - Normally Open Pin C - Normally Closed	5A 125-250 VAC 3A 28 VDC
	IP41	596-EX	Two Pedal - Momentary	Each Pedal SPNO	A	Pin A - Normally Open Left Pedal Pin B - Common Pin C - Normally Open Right Pedal Pin D - Ground	
	IP68	601-EX	Single Pedal - Momentary	SPDT	C	Pin A - Normally Open Pin C - Normally Closed	
	IP68	606-EX	Two Pedal - Momentary	Each Pedal SPNO	A	Pin A - Normally Open Left Pedal Pin B - Common Pin C - Normally Open Right Pedal Pin D - Ground	