



CLIPPER II FOOT SWITCH

The LINEMASTER Clipper II foot switch was designed with an ergonomic shape and zinc die cast housing that will stand the test of time. The Clipper II is offered in single and twin pedal versions and has been the foot switch of choice in many different applications including construction lift equipment and material handling equipment. It offers an EN 60529 Degree of Protection IP65 (IP68 upon request) which is added environmental protection for the harshest conditions. Please contact Linemaster for a quotation for a custom variation built to your specifications.

LIT-058 Rev. B



LINEMASTER Switch Corporation
Tel (860) 974-1000

29 Plaine Hill Rd, P.O. Box 238
Woodstock, Connecticut 06281-0238 USA
Fax (800) 974-FOOT(3668)

www.linemaster.com

CLIPPER II FOOT SWITCH

FEATURES

- Non-skid base pad with durable black finish
- Integral adjustable strain relief clamp
- 1/2"-14 NPT conduit entry
- EN 60529 Degree of Protection IP56
- Steel actuating mechanism with passivated stainless steel springs
- Operating Temperature Range:
-20 Degrees C to +80 Degrees C
- Two holes provided for rigid mounting to the floor or equipment
- Gasket seal provides superior protection from liquids



SINGLE

SIZE (HxWxD): 2.13 x 3.50 x 5.61 In.

WEIGHT: 2.50 lbs.

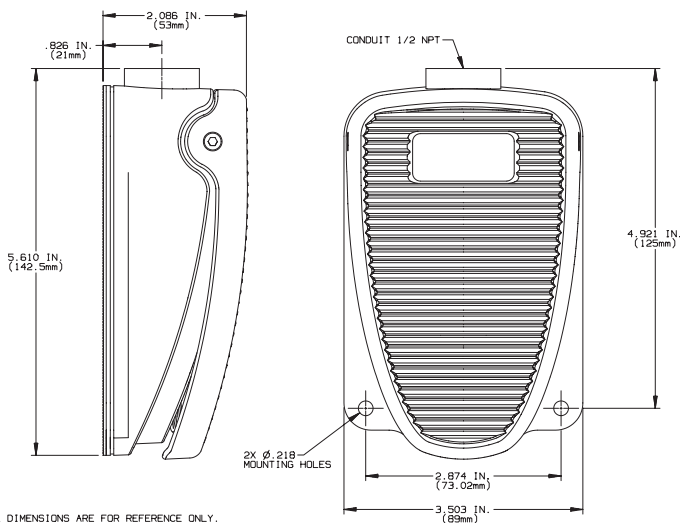

NOTE: ALL DIMENSIONS ARE FOR REFERENCE ONLY.

AGENCY APPROVALS	EN 60529 DEGREE OF PROTECTION	CATALOG NO.	DESCRIPTION	CIRCUIT	FORM	ELECTRICAL RATING
	IP65	911-SZA	Momentary	SPDT	C	20 A 125-250 VAC 1H.P. 125-250-VAC