

AIR - SEAL

FOOT SWITCH



- ▲ The Air-Seal foot switch was designed to operate in various environments, wet or dry, while protecting the customer's critical electrical components. The Air-Seal offers the benefit of isolating the electrically live snap switch from the floor, which also offers environmental protection. Other benefits include long, trouble free, life and suitability for a wide range of applications. Available in momentary and maintained variations with SPDT snap switch mounted in a 9/16" UNF bulkhead mount. The Air-Seal is also supplied with a 10 foot, 1/8" ID PVC tubing that connects from the pedal to the remote air switch. Only from LINEMASTER® - American made innovation at work.



LINEMASTER Switch Corporation
Tel (860) 974-1000

29 Plaine Hill Road, P.O. Box 238
Woodstock, Connecticut 06281-0238 USA
Fax (800) 974-FOOT(3668)

FEATURES:

- Developed for reliable operation in a variety of environments.
- Strong steel housing with long life air bulb mounted in housing.
- Remotely located air operated electric snap switch.
- Supplied with a 10 foot, 1/8" ID, PVC tube connecting from the foot pedal to the remote air switch.
- Heavy gauge steel guards and awareness cover available upon request.
- Weight = .50 lbs.
- Remote switch equipped with a 9/16" U.N.F. bulkhead mount.
- Available in momentary or maintained SPDT versions.
- Isolates the electrically live snap switch from the floor.
- 2 holes provided for rigid mounting to the floor, equipment, or protective guards.
- Mounting plate available on special order.
- Twin models and black tubing available.

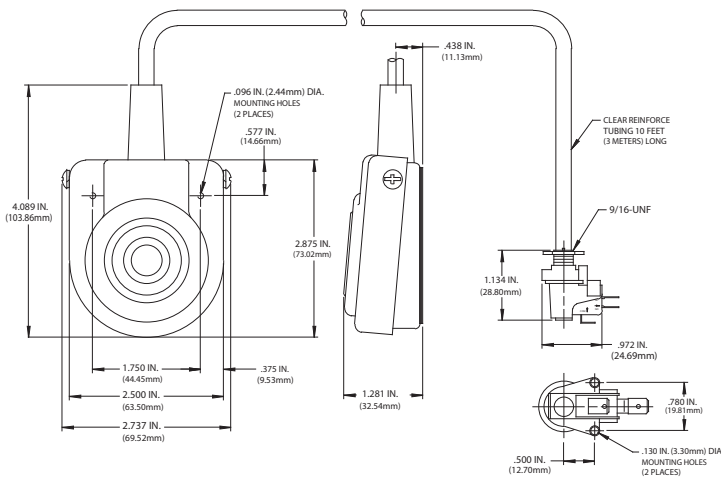

Agency Approvals	EN 60529 Degree of Protection	Catalog Number	Description	Circuit	Form	Operating Temperature Range	Electrical Ratings
	IPXX	41SH12	Momentary	SPDT	C	10° F to 120° F ¹	20A 125-250 VAC 1 H.P. 125-250 VAC
	IPXX	41DH12	Maintained				

¹ The operating temperature range will vary with different lengths of tubing. Please consult the factory for details.