

CLASSIC IV Foot Operated Switch

INSTALLATION

1. **⚠ WARNING: TO AVOID PERSONAL INJURY, DO NOT USE THIS SWITCH ON MACHINERY WITH AN UNGUARDED POINT OF OPERATION.**

⚠ READ WARNING STATEMENT on reverse side of this page.

2. When wiring up this device make sure **POWER IS OFF AND LINES ARE DEAD.**
3. **MAXIMUM FUSE RATING:** Amperage and voltage not to exceed nameplate rating - Quick Acting.
4. Supply cord with flexible conductors (leads) to be prepared as follows (See Diagram "A"):

This device is for use in ordinary locations, **TYPE 1, 2, 4, 6, 6P and 13** and intended to be permanently connected by means of conduit, flexible cord or other system in accordance with **NATIONAL ELECTRICAL CODE.**

When wiring up this device with flexible cord, an **UNDERWRITERS LABORATORIES LISTED** liquidtight connector **MUST BE** provided. Use appropriate thread sealant at assembly to seal connector threads. When threading into conduit opening, **CARE** must be taken to tighten the threaded joint sufficiently to prevent loosening but should **NOT BE FORCED.** The conduit threads must be kept clean from dirt and other foreign materials that would hinder proper installation.

FOR CE MARKED FOOT SWITCHES, PLEASE NOTE THE FOLLOWING: The grounding conductor must be green/yellow in color and be long enough such that the grounding terminal will be the last terminal to take the strain, should the strain relief fail. A cord guard or bend relief must be provided that extends beyond the liquidtight cord connector at least five times the overall diameter of the flexible cord.

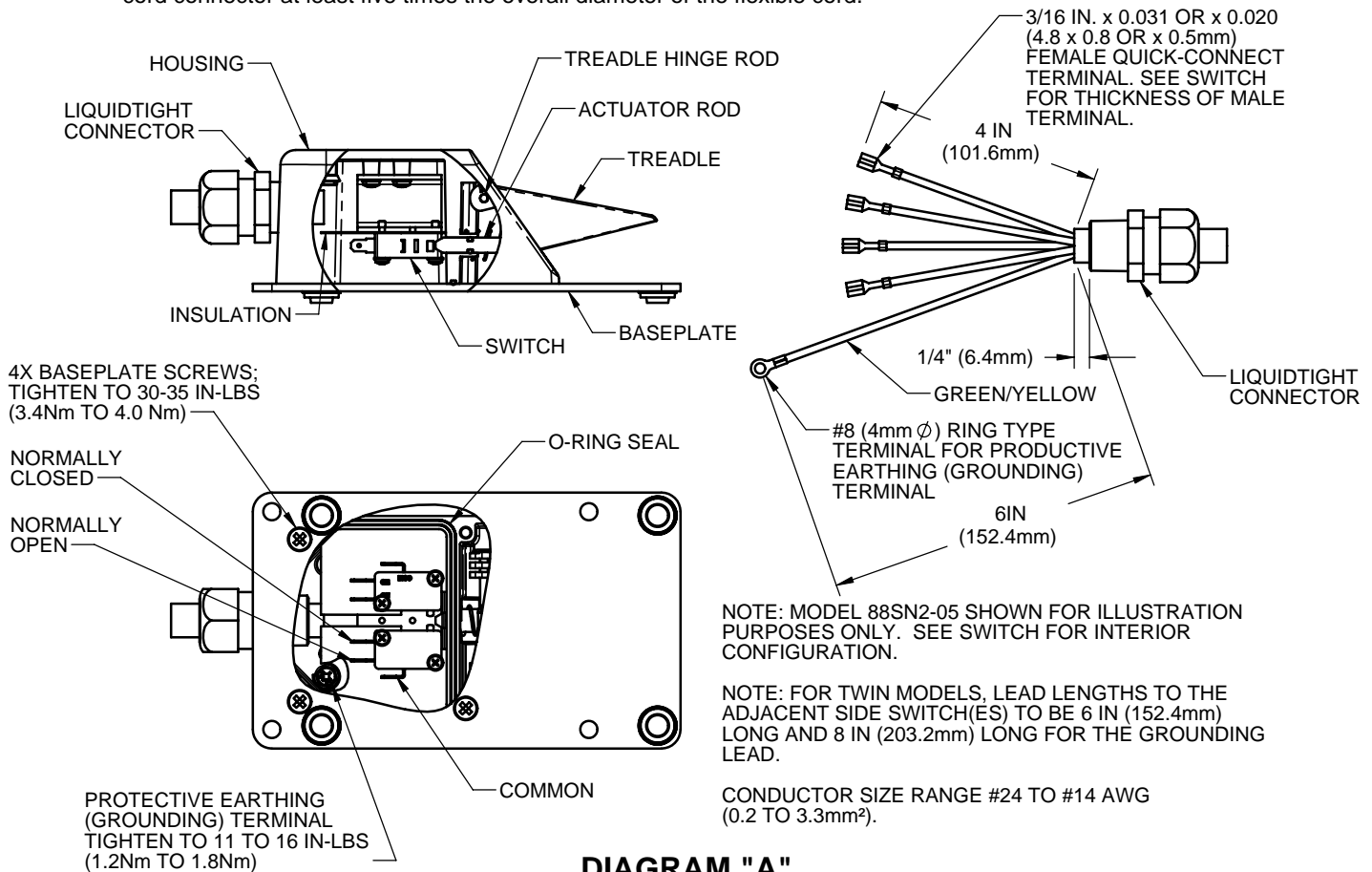

DIAGRAM "A"

5. Tighten the baseplate screws such that an effective seal is obtained with the O-Ring. Tighten to 30 to 35 IN-LBS (3.4 to 4.0 Nm).
6. **CLEANLINESS** must be observed during installation and while in use. On a **REGULAR BASIS**, lubricate the treadle hinge rod, the actuator button and the actuator rod (this passes through the housing).

On a **REGULAR BASIS**, inspect footswitch frequently to guard against wear, damage, unlawful alterations or removal of guards, and for unusual enclosure deterioration and the like. Inspect the entire length of the connecting cord (or wiring system) from where it enters the footswitch to the equipment it's wired up to for wear, loose strain relief connections and the like. **DO NOT OPERATE** if any of the above is observed or if the nameplate and/or warning label has been obscured or removed.

It is **IMPERATIVE** that the inspection authorities and users exercise more than ordinary care with regard to installation and maintenance and that this information sheet be made available to the end user, operators, and maintenance personnel and to others responsible for the proper installation and safe operation of this foot switch.

ADDITIONAL COPIES of this operation sheet and warning labels are available upon request.

 **WARNING**

USE OF FOOT CONTROLS ON MACHINERY LACKING EFFECTIVE POINT OF OPERATION SAFEGUARDS CAN CAUSE SERIOUS INJURY TO THE OPERATOR.

Foot controls should only be used where “Point of Operation” and “Pinch Point” guarding devices have been properly installed and are utilized so that it is **IMPOSSIBLE** for the operator’s hands or fingers to remain within the point of operation during the machine cycle.

IT IS THE RESPONSIBILITY OF THE USER to determine the suitability of a foot control for the user’s intended use and to determine that the foot control chosen by the user and wiring up and installation of the same will comply with all Federal, State and Local safety and health regulations and codes.

Due to the unlimited variety of business equipment, instruments, machines and vehicles on which our foot switches are used, the thousands of standards, and customers’ varying interpretations of the standards covering these applications, it impossible for **LINEMASTER** personnel to be experts on standards and requirements for all these products. We offer over 150 stock foot switch models and guards plus a large variety of specials, which are made to customer specifications. We can advise you what is available in our foot switch line and you can examine models to see what meets your needs. We believe our customers’ engineering departments should be the qualified experts in their own product field and know what specifications or details they require in a foot switch for their equipment. If one of our stock models meets their needs, they can specify it, or possibly ask for a modification of a stock model if that is required.

SHOULD YOU HAVE ANY QUESTIONS OR IF ANY OF THE ABOVE WARNING IS UNCLEAR, PLEASE CALL LINEMASTER SWITCH CORPORATION.

(860) 974-1000; FAX (860) 974-0691 OR (800) 974-3668; www.linemaster.com

READ INSTRUCTIONS on reverse side of this page.

DEFINITIONS:

POINT OF OPERATION - The point or area of the machine or equipment where the work piece or material is actually positioned and work is being performed during any process such as cutting, shearing, punching, forming, welding, riveting, assembling, etc.

PINCH POINT - Any point at which it is possible for a portion of the body to be caught and injured between moving machine or equipment or work piece parts.

Form #977-K9

NOTE:

BLACK PRINTING ON 8.5" x 11" WHITE PAPER.
FOLDED SIZE: 5.500" x 4.250" WITH WARNING OUT.
BOTH SIDES OF FORM MUST BE ORIENTED THE SAME.

DR: DAP DATE: 03/02/06 APPV: DATE:

REVISIONS:

LEVEL	DATE	DESCRIPTION
A	03/02/06	RELEASED TO PRODUCTION. (ECN 0600128) DAP
B	04/05/06	REVISED TORQUE VALUE IN DIAGRAM "A" AND NOTE 5, 30 to 35 WAS 20 to 25. (ECN 0600378) DAP
C	05/05/06	CHANGED TITLE BLOCK TO BE CLASSIC IV; WAS CLASSIC III (ECN 0600248) EPG
D	11-29-06	Sheet #2 was not saved as revision C (was still B). Revised both sheets to revision D. (KG)
E	06-18-09	See revision page @ F:\Files\Revision Pages\977