

# SLIM-LINE Foot Operated Switch

## WIRING

- ⚠ WARNING: TO AVOID PERSONAL INJURY, DO NOT USE THIS SWITCH ON MACHINERY WITH AN UNGUARDED POINT OF OPERATION.**  
**⚠ READ WARNING STATEMENT** on reverse side of this page.
- When wiring up this device make sure **POWER IS OFF AND LINES ARE DEAD.**
- MAXIMUM FUSE RATING:** Amperage and voltage not to exceed nameplate rating – Quick Acting.
- Supply cord with flexible conductors (leads) to be prepared as shown. (See Diagram "A").  
 For solder connections: Strip inner leads 3/16 in. (4.8mm) and tin. Form 180° loops and trim excess after making a mechanical connection and prior to soldering.  
**NOTE:** For CE Marked foot switches, a cord guard or bend relief must be provided that extends beyond the cord clamp at least five times the overall diameter of the flexible cord.

DIAGRAM "A"

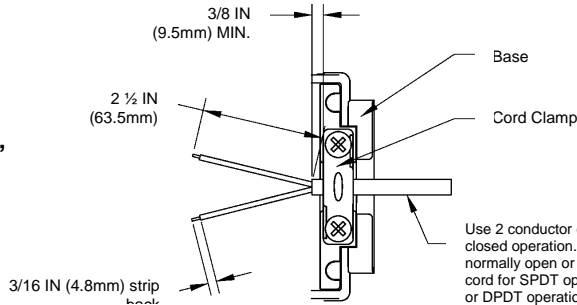
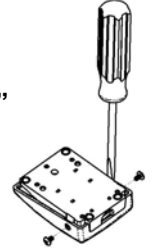

DIAGRAM "B"



Remove cover screws prior to removing the cover

Use 2 conductor cord for single pole normally open or normally closed operation. Use 4 conductor cord for 2X single pole normally open or normally closed operation. Use 3 conductor cord for SPDT operation. Use 6 conductor cord for 2X SPDT or DPDT operation. Minimum flexible conductor size: #18 AWG (.80 mm<sup>2</sup>) for up to 10 feet. Maximum outer diameter of cord shall be .400 (10.2mm) diameter.

- Remove cover from base by removing the two cover screws and prying the cover with a flat blade screwdriver on either side shown in Diagram "B" and remove snap switches (packed loose) for wiring. Care must be observed to prevent damage to cover and base.
- Solder cord leads to the appropriate switch terminals.
- Loosen or remove cord clamp screws, insert cord and re-attach cord clamp. (See Diagram "A").
- Insert snap switches over posts in base and push down evenly until they are completely seated in the base. (See Diagram "C" for appropriate switch model and snap switch orientation). If snap switch removal is necessary, care must be taken to avoid damaging the alignment posts.
- Verify that the internal parts are working properly by pressing down on the button part and hearing an audible click. Incidental removal of lubricant is acceptable.

DIAGRAM "C"

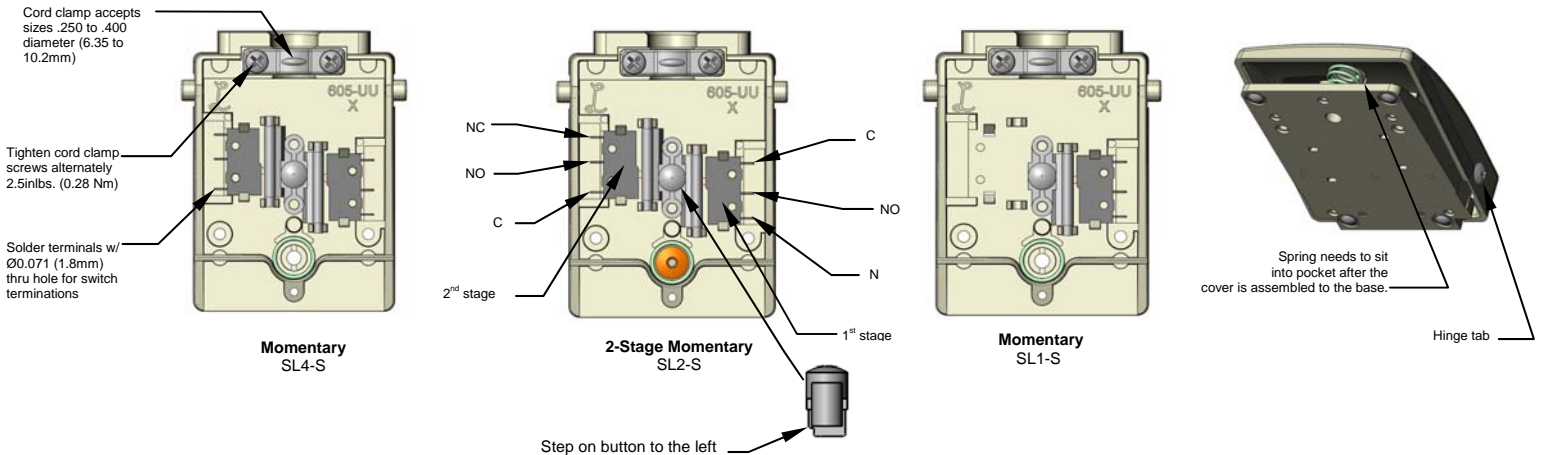

- Re-assemble cover to base by snapping onto hinge tabs and re-install the cover screws. Torque to 2.5 IN-LBS (.28 Nm).
- CLEANLINESS** must be observed during installation and in use on a **REGULAR BASIS**, inspect foot switch frequently to guard against wear, damage, unlawful alterations or removal of guards, or for unusual enclosure deterioration and the like. Inspect the entire length of the connecting cord (or wiring system) from where it enters the foot switch to the equipment it is wired up to for wear, loose strain relief connections, and the like. **DO NOT OPERATE** the foot switch if any of the above is observed or if the nameplate or warning label has been obscured or removed. It is **IMPERATIVE** that inspection authorities and users exercise more than ordinary care with regard to installation and maintenance and that this information be made available to the end user, operators, and maintenance personnel and to others responsible for the proper installation and safe operation of this foot switch.
- CLEANING** can be done by using a damp, non-abrasive cloth with one of the following products. Isopropyl alcohol, soap and water, Cidex, or Sodium Hypochlorite 5.25% (Bleach) diluted 10:1, then wring out until slightly wet and gently rub soiled area until clean. **CAUTION:** Do not immerse switches, cables or connectors in or under running water or cleaning fluids. Exceptions: IP68 rated only switches can be completely immersed **briefly** in solutions listed above **only**.

**ADDITIONAL COPIES** of this information sheet and warning labels are available upon request.

## MOUNTING

- Slim-Line foot operated switches are furnished with 4 non-skid base feet that must be removed prior to mounting to any surface.
- Use (2) #4 thread-forming screws when mounting foot switch to full guard 522-B14. Use (3) #4 thread forming screws and (3) #4 countersink lock washers when mounting foot switch to Awareness cover 522-D34 (See Diagram "D")

DIAGRAM "D"

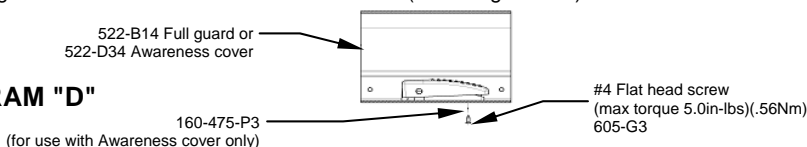

## CORD WIRING SCHEMATIC

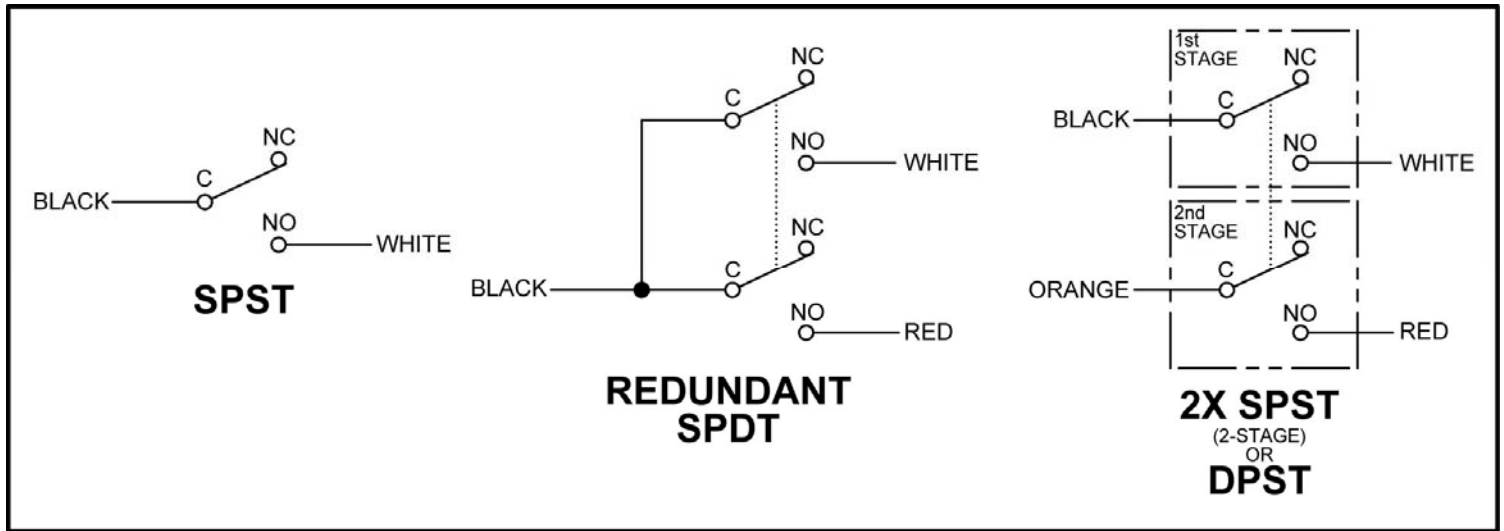

## WARNING

**USE OF FOOT CONTROLS ON MACHINERY LACKING EFFECTIVE POINT OF OPERATION SAFEGUARDS CAN CAUSE SERIOUS INJURY TO THE OPERATOR.**

Foot controls should only be used where "Point of Operation" and "Pinch Point" guarding devices have been properly installed and are utilized so that it is **IMPOSSIBLE** for the operator's hands or fingers to remain within the point of operation during the machine cycle.

**IT IS THE RESPONSIBILITY OF THE USER** to determine the suitability of a foot control for the user's intended use and to determine that the foot control chosen by the user and wiring up and installation of the same will comply with all Federal, State and Local safety and health regulations and codes.

Due to the unlimited variety of business equipment, instruments, machines and vehicles on which our foot switches are used, the thousands of standards, and customers' varying interpretations of the standards covering these applications, it is impossible for **LINEMASTER** personnel to be experts on standards and requirements for all these products. We offer over 150 stock foot switch models and guards plus a large variety of specials, which are made to customer specifications. We can advise you what is available in our foot switch line and you can examine models to see what meets your needs. We believe our customers' engineering departments should be the qualified experts in their own product field and know what specifications or details they may require in a foot switch for their equipment. If one of our stock models meets their needs, they can specify it, or possibly ask for a modification of a stock model if that is required.

**SHOULD YOU HAVE ANY QUESTIONS OR IF ANY OF THE ABOVE WARNING IS UNCLEAR, PLEASE CALL LINEMASTER SWITCH CORPORATION.**

(860) 974-1000; FAX (860) 974-0691 OR (800) 974-3668; [www.linemaster.com](http://www.linemaster.com)

**READ INSTRUCTIONS** on reverse side of this page.

### DEFINITIONS:

**POINT OF OPERATION** - The point or area of the machine or equipment where the work piece or material is actually positioned and work is being performed during any process such as cutting, shearing, punching, forming, welding, riveting, assembling, etc...

**PINCH POINT** - Any point at which it is possible for a portion of the body to be caught and injured between moving machine or equipment or work piece parts.

# Form 605-GG

<b>Paper Size:</b>	8.5" x 11"	<b>Folded Size:</b>	2.75"x 4.25"
<b>Notes:</b> Black printing on white paper, with Warning out.			
<b>Drawn by</b>	<b>Date</b>	<b>Approved by</b>	<b>Date:</b>
EPG	6/13/06	DAP	06-19-06
<b>Revision</b>	<b>Date</b>	<b>ECN</b>	<b>Description</b>
1	6/13/06	0600286	PRELIMINARY RELEASE (EPG)
2	9/10/07	0700285	CHANGES DUE TO REDESIGN (EPG)
3	2/20/08	0800041	REMOVED MAINTAINED VERSION AND REWORDED DESCRIPTIONS (EPG)
A	2/22/08	0800067	REWORDED INSTRUCTION, ADDED 'CORD WIRING SCHEMATIC', RELEASED TO PRODUCTION. (EPG)
B	10/08/08	0800207	REVISED CORD WIRING SCHEMATIC, ORANGE COLOR LEAD WAS GREEN. DELETED NOT USED LEAD WIRE LINES. (DAP)
C	01/16/09	0900008	REVISED COVER REMOVAL INSTRUCTIONS TO ADD COVER SCREW INFORMATION AND SHOW COVER SCREWS IN THE APPROPRIATE VIEWS. CORRECTED INTERIOR VIEWS TO BE PICTORIALY CORRECT. (DAP)
D	02/12/09	0900057	REVISED CORD CLAMP SCREW TIGHTENING TORQUE, 2.5 INLBS. (0.28 NM) WAS 5-6 INLBS. (.6-.7 NM). (DAP)
E	12-06-11	1100352	REVISED CORD WIRING SCHEMATIC SPDT TO BE REDUNDANT SPDT. (KG)