



TREADLITE II Foot Operated Switch

WIRING =====

-  **WARNING: TO AVOID PERSONAL INJURY, DO NOT USE THIS SWITCH ON MACHINERY WITH AN UNGUARDED POINT OF OPERATION.**
 **READ WARNING STATEMENT** on reverse side of this page.
- When wiring up this device make sure **POWER IS OFF AND LINES ARE DEAD**.
- MAXIMUM FUSE RATING:** Amperage and voltage not to exceed nameplate rating – Quick Acting.
- Supply cord with flexible conductors (leads) to be prepared as shown. (See Diagram "A")
 Supply cord with prepared flexible conductors. Use special purpose crimping tool to apply ring terminal to conductor. Use special silicone filled wire nuts supplied with foot switch for interior switch connections.

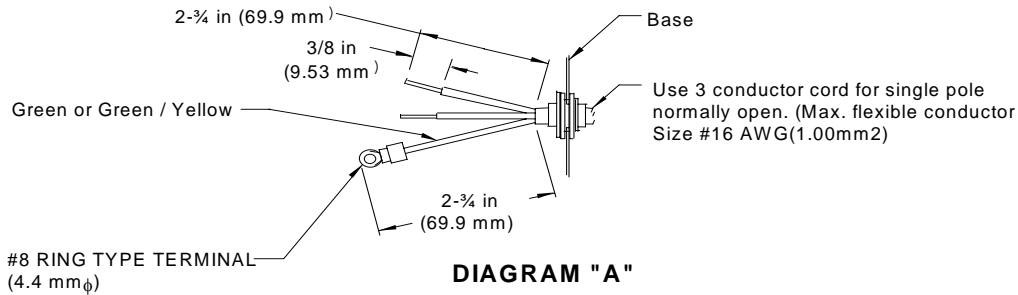

- Remove hinge screws and detach cover and cover return spring from base. (See Diagram "B").

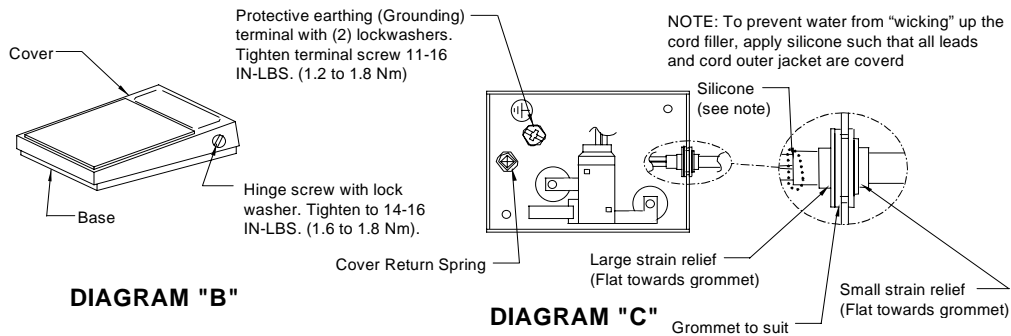

- Re-assemble cover return spring and cover to base with hinge screws and lockwashers.

- CLEANLINESS** must be observed during installation and in use.

On a **REGULAR BASIS** inspect foot switch frequently to guard against wear, damage, unlawful alterations or removal of guards, or for unusual enclosure deterioration and the like. Inspect the entire length of the connecting cord (or wiring system) from where it enters the foot switch to the equipment it's wired up to for wear, loose strain relief connections and the like. **DO NOT OPERATE** the foot switch if any of the above is observed or if the nameplate or warning label has been obscured or removed.

It is **IMPERATIVE** that inspection authorities and users exercise more than ordinary care with regard to installation and maintenance and that this information sheet be made available to the end user, operators, and maintenance personnel and to others responsible for proper installation and safe operation of this foot switch.

ADDITIONAL COPIES of this information sheet and warning labels are available upon request.

MOUNTING =====

- Treadlite II foot operated switches are furnished with a non-skid base pad and can be mounted with the base pad attached.
- Use two number 4 thread-cutting (self-tapping) screws and two number 4 lock washers when mounting to full guard. (See diagram "D").

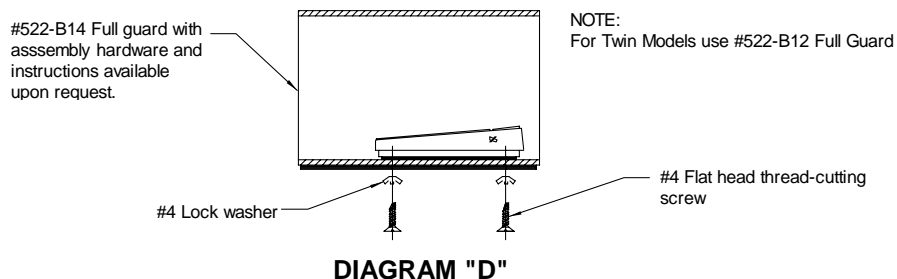

WARNING

USE OF FOOT CONTROLS ON MACHINERY LACKING EFFECTIVE POINT OF OPERATION SAFEGUARDS CAN CAUSE SERIOUS INJURY TO THE OPERATOR.

Foot controls should only be used where “Point of Operation” and “Pinch Point” guarding devices have been properly installed and are utilized so that it is **IMPOSSIBLE** for the operator’s hands or fingers to remain within the point of operation during the machine cycle.

IT IS THE RESPONSIBILITY OF THE USER to determine the suitability of a foot control for the user’s intended use and to determine that the foot control chosen by the user and wiring up and installation of same will comply with all Federal, State and Local safety and health regulations and codes.

Due to the unlimited variety of business equipment, instruments, machines and vehicles on which our foot switches are used, the thousands of standards, and customers’ varying interpretations of the standards covering these applications, it is impossible for **LINEMASTER** personnel to be experts on standards and requirements for all these products. We offer over 150 stock foot switch models and guards plus a large variety of specials, which are made to customer specifications. We can advise you what is available in our foot switch line and you can examine models to see what meets your needs. We believe our customers’ engineering departments should be the qualified experts in their own product field and know what specifications or details they may require in a foot switch for their equipment. If one of our stock models meets their needs, they can specify it, or possibly ask for a modification of a stock model if that is required.

SHOULD YOU HAVE ANY QUESTIONS OR IF ANY OF THE ABOVE WARNING IS UNCLEAR, PLEASE CALL LINEMASTER SWITCH CORPORATION.

(860) 974-1000; FAX (860) 974-0691 OR (800) 974-3668.

www.linemaster.com

READ INSTRUCTIONS on reverse side of this page.

DEFINITIONS:

POINT OF OPERATION - The point or area of the machine or equipment where the work piece or material is actually positioned and work is being performed during any process such as cutting, shearing, punching, forming, welding, riveting, assembling, etc..

PINCH POINT - Any point at which it is possible for a portion of the body to be caught and injured between moving machine or equipment or work piece parts.

Form #515-D34

NOTE:

BLACK PRINTING ON 8.5" x 11" WHITE PAPER.
FOLDED SIZE: 4.125" x 2.875" WITH WARNING OUT.
BOTH SIDES OF FORM MUST BE ORIENTED THE SAME.

DR: ADG DATE: 12-09-98 APPV.: RDC DATE: 12-09-98

REVISIONS:

LEVEL	DATE:	DESCRIPTION
A	03-10-99	Revised to be purchased part. (ECN 003504)(TJF)
B	01-02-03	Added over current protection statement and added Linemaster web site address.
C	01-17-03	Revised numbering on sheet 1 (ECN 010451)(JTL)
D	06-18-09	See revision page @ F:\Files\Revision Pages\515